



## **Rideau Valley Conservation Authority**

3889 Rideau Valley Drive, Manotick, Ontario, Canada K4M 1A5 | 613-692-3571 | [www.rvca.ca](http://www.rvca.ca)

---

### **Technical Memorandum**

**Date:** June 14, 2011

**Subject:** **Analysis of Regulatory Flood Level on the Shoreline of Otter Lake, for the purposes of administering Ontario Regulation 174/06**

**Lead Investigator<sup>1</sup>:** Ferdous Ahmed, Ph.D., P.Eng.  
Senior Water Resources Engineer

**Contributing staff:** Stephanie Schreiner, Engineering Assistant  
Ewan Hardy, GIS Coordinator  
Ahmed B. Ahmed, Engineering Intern  
Thomas Ducrocq, Engineering Intern  
Lisa Vadeboncoeur, GIS Technician

---

#### **Abstract**

This paper provides a summary of the background information, simplifying assumptions and hydrologic and hydraulic analysis methods used to generate a reasonable estimate of the Regulatory (1:100 year) Flood Level for Otter Lake. An attempt was also made to identify the approximate extent of lands that may be inundated under that water level, which was not successful due to the limitations of available topographical information. This study supports the plotting of Regulation Limits Mapping for the Lake. The study area, consisting of the Otter Lake watershed is depicted in Figures 1 and 2.

The completed analysis meets or exceeds the standards for “approximate methods for estimating flood plains” as provided for in “Guidelines for Developing Schedules of Regulated Areas” (Conservation Ontario, 2005).

---

<sup>1</sup> The extensive guidance provided by Bruce Reid is gratefully acknowledged.

## **Introduction**

The development and site alteration control provisions of Ontario Regulation 174/06 apply in all areas within the RVCA area of jurisdiction meeting criteria set out in Ontario Regulation 97/04 (the so-called “generic regulation”), including areas that are adjacent to inland lakes and could be affected by flooding under 1:100 year flood conditions, or by erosion and slope failure processes. Over time, and as resources enable it, RVCA is working to complete its inventory of regulation limits mapping to explicitly delineate the areas that are subject to the regulation. Doing so will better inform the general public, landowners and RVCA staff as to where the regulations are in effect and are to be enforced.

There are numerous inland lakes in the RVCA area of jurisdiction for which there has been no previous attempt to define regulatory (1:100 year) flood levels and corresponding estimated flood lines. Otter Lake was selected as a test case for the development of an approximate method for determining the flood level that is suitable for use on lakes that perform no artificial flow regulation or water storage function, and where the historical record of outflow discharge or annual maximum water level is insufficient for the use of statistical methods (single station frequency analysis). A three step process has been developed:

Step 1 – estimation of the 1:100 year flow at the lake’s outlet. Initially, flood flows at the outlets of all the lakes in the RVCA’s area of jurisdiction were estimated using a number of methods (RVCA, 2010). Various methods, borrowed from scientific research papers, handbooks and guideline documents, were applied and compared with a view to identifying a probable range of values for the 1:100 year discharge for each lake. The selection of a recommended 1:100 year discharge value for any particular lake (e.g., Otter Lake) would then be made through closer examination of all of the available streamflow and water level information that is available for that lake and its receiving stream, and consideration of its natural runoff storage and release function (which depends on the lake’s area and the physical characteristics of its outlet).

Step 2 – computation of the lake level that corresponds with the 1:100 year flow at the lake’s outlet, using information about the physical characteristics of the lake’s

outlet that determine its hydraulic (flow) capacity, as well as the lake's runoff storage capacity. For Otter Lake, surveys of the outlet channel and the configuration of the Otter Lake Road and culvert were completed.

Step 3 – estimated flood lines corresponding to the 1:100 year water surface elevation are then plotted using available topography of the shorelines around the lake. For most of the lakes in the RVCA area of jurisdiction, the best available topographic information is available in two formats:

- 1:10,000 scale OBM (Ontario Base Mapping) with a 5 m contour interval
- 10 m x 10 m Digital Elevation Model (DEM) compiled by MNR in 2006

Floodline plotting can be automated using computer programs and the DEM, or done manually by interpolating between the 5 metre contours. The two methods may yield differing results (in terms of the plotted position of the flood line in plan view), but neither line would be considered to more accurately reflect the true position of the flood line on the ground than the other. An attempt was made to plot the flood line using the DEM. It was found that the resolution of the DEM (10x10m) is such that local topographic features at the scale of typical shoreline properties may not be accurately reflected in the DEM. Also, the stated vertical accuracy of the DEM is  $\pm 2.5$  metres. Accordingly the flood lines estimated this way would only be a crude approximation, compared to the accuracy that has in the past been required for engineered flood line mapping. They may therefore not be suitable for RVCA regulation limits mapping purposes or for use in designating hazard lands for municipal zoning purposes.

## **Study Area**

Otter Lake has a surface area of 572 hectares and a shoreline length of 22.8 km. The catchment area draining to the lake is 36.38 km<sup>2</sup>.

The study area includes the watershed of Otter Lake as shown in Figures 1 (aerial photo base) and Figure 2 (DEM base). Ideally, regulation limits are to be produced for the entire shoreline of Otter Lake and adjacent low-lying areas based on the estimated flood lines for the 1:100 year water surface elevation. Otter Lake Road was assumed to

act as the “hydraulic control” for lake levels during extreme runoff events and is therefore the downstream boundary of the study area.

The entire study area is within the Township of Rideau Lakes. There is no major centre of settlement around the lake or in the study area, but many (300+) lakeside cottages and rural residences.

### **Hydrological Analysis**

There are no historical streamflow records for Otter Creek. Local residents have been recording water levels at the Otter Lake Road culvert on a non-continuous basis since 2003. These data may or may not include actual annual maximum water levels, the period of record is short (8 years), and outlet conditions during that time were variable as a result of beaver activity in the outlet channel downstream of Otter Lake Road. Statistical analysis methods (frequency analysis) can not be used because of these limitations in the historical records.

As described in RVCA (2010), flood flows for the Otter Lake outlet were previously computed using a number of methods, as follows (Table 1, Figure 3):

- FDRP regression (Ontario)
- FDRP regression (Eastern Ontario)
- FDRP regression (Northern Ontario)
- Gingras et al.’s equation (Region 7)
- Gingras et al.’s equation (Region 6)
- Gingras et al.’s equation (Ontario/Quebec)
- Mike11 long term simulation (1940 to 2007)
- Area-prorating using Rideau River flow at Carleton

Details of these methods and their computation are described in RVCA (2010), and are not repeated here. That analysis concluded that in general, and in the absence of more rigorous hydrologic analysis for any given lake, the 1:100 year discharge should be

selected from amongst the range of values derived from the three “FDRP” regression equations, based on local considerations. In this examination of the Otter Lake situation, the 1:100 year flood discharge derived from long term hydrologic simulation using RVCA’s MIKE 11 model was also considered (see Figure 3).

The original Mike11 model, encompassing the whole Middle Rideau subwatershed, was done at a regional scale and did not account for the Otter Lake outlet (the existing CSPA culvert under the Otter Lake Road). As a part of this study, a new local-scale model for the Otter-Hutton system was built which included the lake outlet (Figure 15). This system was simulated from 1940 to 2007. Ignoring the first three years to avoid effects of initial condition, the remaining 65 years of simulated flow data (1943 to 2007) at the outlet of Otter Lake was used for flood frequency analysis using the CFA program of Environment Canada (Pilon and Harvey, 1993). The flood quintiles derived from this analysis are listed in Table 1 and plotted in Figure 3.

The design flows estimated by this local-scale Mike11 model<sup>2</sup> that takes into account the outlet culvert was found to be the most defensible estimate, based on the following:

1. Located to south and east of the “Frontenac Arch” extension of the Precambrian Shield, Otter Lake’s catchment area is more characteristic of the Eastern Ontario hydrologic region, than the Northern Ontario hydrologic region, therefore the FDRP (Northern) equation was deemed inappropriate for use on Otter Lake.
2. Based on the eight years (2003-2011) of measured water level data for Otter Lake (Figure 4), one might expect roughly four occurrences of a 1:2 year flow (or higher) to have been observed during that period; meanwhile the 1:2 year flow derived from the FDRP (Eastern Ontario) equation was 7.50 cms, corresponding to a water level of 126.10 m – higher than any of the observed water levels over the last eight years. This indicates that the

---

<sup>2</sup> We have designated this as Mike11 (with outlet culvert) as opposed to the original regional scale Mike11 model designated as Mike11 (without outlet culvert). For, as we found, the presence of the culvert influences the outflow from the lake and thus the design flood. Therefore, lake outlet structures not only pass the design flood but also determines its magnitude to certain extent.

- FDRP (Eastern) equation over-estimates the outlet flow. The same can be said about the FDRP (ON) method with a 1:2 year flow of 3.77 cms (associated with a water level of 125.50 m) and Mike11 (without outlet culvert) with a 1:2 year flow of 4.52 cms (associated with a water level of 125.53 m).
3. The 1:2 year flow derived from the Mike11 (with outlet culvert) model is 2.01 cms with an associated water level of 125.17 m. This level was exceeded three times during the last eight years, which is slightly lower than the four occurrences expected from simple statistical considerations.
  4. The 1:10 year flows from FDRP (Eastern), FDRP (ON), Mike11 (without outlet culvert) and Mike11 (with outlet culvert) are 10.35, 6.39, 6.12 and 3.09 cms respectively, with associated water levels of 127.10, 125.85, 125.79 and 125.30 m respectively. All of these levels are higher than the measured water levels during the last eight years, which indicated that all these flow estimates are on the conservative (high) side. However, the Mike11 (with outlet culvert) estimate was, although conservative, the least incongruent with the measurements.
  5. Finally, the volume of runoff required to raise the lake level to the estimated flood level (expressed as a depth of water over the entire catchment area of the lake), was compared with the magnitude of a 1:100 year snowmelt plus rain event over the catchment, as a check on the reasonableness of discharge prediction. The runoff volume required to raise the water level to the water level associated with the higher discharge estimate from the FDRP equations was found to be well in excess of any reasonable estimate of the runoff volume for a 1:100 year event. It appears that while the FDRP equations generally account for the area of the catchment that is controlled by lake storage (ACLS), that term in the regression equation does not apply well to small watersheds where the outflow location (or flow calculation node) is at outlet of a lake with a relatively large surface area in relation to the total area of the catchment –

as is the case here, where the surface area of Otter Lake is 16% of the catchment area). Meanwhile, Mike 11's hydrodynamic river flow simulation inherently accounts for the flow attenuating effect of the lake by treating it as a long river reach with an extra wide cross-section.

Considering all information available and based on the considerations outlined above, it is recommended that the discharge estimates derived from the MIKE 11 (with outlet culvert) long-term simulation be used as the most appropriate for flood risk determination on the shorelines of Otter Lake. The design flows are shown in Table 3.

The flows listed in Table 3 have been used in the hydraulic analysis to determine the corresponding flood levels.

### **Data Used**

Aerial Photo: The available DRAPE aerial photo was collected in May and June of 2008 for the entire RVCA area of jurisdiction. This high quality colored photo (Figure 1) clearly shows the rivers, creeks, land use, houses, buildings, roads, infrastructure, vegetation and other details.

Historic Aerial Photo: As shown in Figure 5, historical photos in this vicinity since the 1950s are available. These photos show lakeshore, watercourses and road layouts, but do not clearly show the road crossing at the Otter Lake outlet. However, the photos do indicate that at some time between 1953 and 1978 the bridge or culvert under the Otter Lake Road was relocated to the west of its original position and the low flow channel was re-aligned.

DEM: The 10 x 10 m grid DEM was provided by MNR in 2006 (Figure 2). It has an accuracy of 1.5 m horizontally and 2.5 m vertically. Contour lines at 1 m intervals, and also corresponding to any specified elevation (e.g., 1:100 year flood elevation), can be generated from this DEM using GIS software to enable automated plotting of the flood line instead of more labour intensive interpolation between the 5 metre contours of the OBM maps.

Outlet Culvert: The 15.3 m long, 2.44 m wide and 1.75 m high corrugated steel pipe arch (CSPA) culvert under the Otter Lake Road acts as the outlet control of the lake under high flow conditions (Figures 6, 7 and 8). Information on the culvert and the associated road profile is not available from as-built drawings, and was obtained by field surveys undertaken by RVCA technologists.

Rock Ledge: An elevated rock ledge located about 250 m downstream of the Otter Lake Road culvert, controls the tailwater condition at the culvert and the lake level during low flows and frequently occurring runoff events. The cross-section at this location was surveyed (Figure 9).

Measured Water Level: Since 2003, periodic water level measurements of the lake water level near the outlet of Otter Lake have been taken by both RVCA and local residents. This information (Figure 4) has been utilized in the present study.

## **Hydraulic Calculations**

For a given estimate of the discharge, the headwater level is determined by the tailwater level (i.e. the water level at the outlet of the culvert), and the hydraulic head required to overcome the energy losses associated with expansion and contraction of the flow at the culvert inlet and outlet, and friction along the length of the conduit (see Figure 10). Culvert design charts in the MTO (1985) Manual have been used to determine the upstream water surface elevation at the Otter Lake Road culvert. This is the most widely used and accepted method in Ontario<sup>3</sup>.

The type of flow (inlet or outlet control) and tailwater level are important considerations in determining the headwater level. Typically, headwater levels are determined for both “inlet control” and “outlet control” conditions, and the one producing higher headwater is taken as the governing condition. Tailwater level for the design condition is often difficult to determine with accuracy unless there is an identified

---

<sup>3</sup> Most of the culvert calculation methods (MTO 1985; MTO 1997; FHWA 2001) and software (Haestad Methods 2007) currently in use are based on the original research done by FHWA (1965). We have verified that MTO (1985) Manual gives almost the same results as the other methods. Standard textbooks (e.g., Sturm 2010) also follow the same source, although older texts such as Smith (1995) refer to research done in 1950s.



downstream hydraulic control and/or reliable hydraulic (backwater) modeling of the downstream watercourse. In the absence of a better estimate, MTO (1985) suggests, for culvert design purposes, using the average of the culvert diameter and the critical depth associated with the design flow as an assumed tailwater depth.

In the case of Otter Lake, the rock ledge about 250 m downstream of the culvert (Figure 9), sets up a tailwater level at the culvert under low flow conditions at an elevation of at least 124.2 m (about 0.2 m above the culvert invert) plus the depth of flow at the rock ledge cross-section itself. (This assumes the channel is free of obstructions such as beaver dams or debris blockages). During extreme events, the rock ledge is expected to have less of a controlling effect on the culvert tailwater level, since overbank flow on the flood plain overbanks will occur and/or the ledge could be submerged by a further downstream control. Using the MTO approach (Figure 11), the assumed tailwater level for upstream flood level estimation purposes and the 1:100 year flow of 4.3 cms is 125.26 metres above sea level.

Water levels on the lake are influenced by beaver activity in the outlet channel. At the present time efforts to manage the beaver population and breach their dams are being made with the objective of keeping the water surface elevation close to an elevation of 124.86 metres above sea level (34 inches below the obvert of the CSPAs) for “normal conditions”. The assumed tailwater level at the culvert for 1:100 year conditions is 0.40 metres higher than this level, and is similar to the highest water levels recorded at the culvert by local residents, which were influenced by beaver dams at the rock ledge and elsewhere along Otter Creek.

After adopting an assumed tailwater level, another MTO (1985) nomograph (Figure 12) was used to determine the headwater corresponding to the design flow. Several parameters (i.e., culvert length of 15.3 m; projecting entrance with a coefficient of 0.9; Manning’s roughness of the culvert at 0.032) were used as inputs. The headwater was computed for the flows estimated by Mike11 models (both with and without outlet culvert), as listed in Table 2, to illustrate the degree to which the selection of the 1:100 year design flow affects the adoption of a regulatory flood level for the lake. The

resulting culvert rating performance curve (upstream water surface elevation vs. discharge) is shown in Figure 13.

The CulvertMaster software of Haestad Methods (2007) was also used to check our results. It replicates the MTO (1985) results closely.

Calculation of wave rush-up is recommended by MNR (1986, 2002) for flood plain delineation on inland lakes with an effective fetch length longer than 3 km. The Guidelines for Developing Schedules of Regulated Areas (Conservation Ontario, 2005) do not require accounting for wave rush-up on lakes that are less than 100 km<sup>2</sup> in surface area. The effective fetch length for Otter Lake is estimated to be in the range of 1.3-1.7 km using US Corps of Engineers' (1977) method. Therefore, consideration of wave rush-up is not necessary for Otter Lake, regardless of which Guideline is followed.

### **Summary of Conclusions from Hydrologic and Hydraulic Analyses**

The recommended regulatory flood level for Otter Lake is 125.50 metres above sea level, and is associated with a discharge of 4.3 cms at the Otter Lake Road culvert, the present configuration of the culvert and downstream channel, and an assumed tailwater level of 125.26 metres above sea level.

This regulatory flood level is 0.64 m (25½ inches) above the informally adopted “interim target” level for the Lake (124.86 m), or 0.21 m (8½ inches) below the obvert (top) of the CSPA culvert inlet.

The highest recorded water level (in the 2003-2011 period) was 0.48 m (19 inches) below the obvert of the culvert inlet or 125.24 metres above sea level. This level was recorded on April 13, 2008 when beaver dams were present in the outlet channel, corresponds to a 1:5 year event (Table 2), and was only 0.26 m (10½ inches) lower than the estimated 1:100 year flood level. During that event, RVCA was made aware of a few inundated access roads and shoreline properties on the lake. Elsewhere in the Rideau River watershed, the April 2008 spring freshet generated streamflows in the 1:5 year to 1:10 year return period range. These observations lead to these conclusions:

- there is a need for ongoing attention to the beaver activity (dams) on Otter Creek to avoid excessive tailwater levels at the Otter Lake culvert at the onset of an extreme runoff events
- under 1:100 year flood conditions, even with maintenance of the outlet channel, some access routes to shoreline properties can be expected to be inundated to greater depths than they were in April 2008

The “head loss” (i.e., the difference between upstream and downstream water levels) through the Otter Lake culvert under 1:100 year flood conditions has been estimated to be 0.24 metres (9½ inches), which is typical of any bridge or culvert, and is not considered to be excessive.

### **Flood Line Delineation and Regulation Limits**

Ideally, once the Regulatory Flood Level is established, the plotting of 1:100 year flood lines or flood risk limits around the lake is a relatively straightforward matter. As previously noted, using the available topographical information (the 10 x 10 m DEM received from MNR in 2006), we made an attempt to draw approximate elevation contour lines at 1 metre intervals and the estimated flood line at 125.50 metres above sea level. The Regulation Limit line would then be plotted the prescribed 15 metres upland of the estimated flood line, wherever the extent of the flood hazard area limit is greater than the extent of wetlands or erosion and slope stability hazards.

However, because of the low horizontal resolution and stated vertical accuracy of the digital elevation model, it does not accurately represent the actual topography of shoreline properties, and the resulting estimated flood lines do not accurately identify areas that are affected by flooding under regulatory flood conditions and are, therefore, subject to the regulations.

Until topographic mapping or digital elevation models of better accuracy and resolution becomes available, identifying the boundaries of hazardous lands with

reasonable confidence will require on-site inspections and/or aerial photograph interpretation if suitable imagery is available.

The Regulatory Flood Level of 125.50 metres above sea level should be used when assessing the safe access/egress and flood proofing aspects of development applications in the regulated area.

### **Regulation Policy Recommendations**

Because of the large surface area of Otter Lake relative to its catchment area, the lake has a considerable flow attenuating effect during major runoff events. The runoff storage volume associated with inundated low-lying lakeshore properties is insignificant compared with the storage volume on the lake itself. It follows that the flood hydrograph attenuating function of the lake will not be significantly diminished by the minor loss of storage capacity that would be associated with typical shoreline development.

In general, therefore, development of shoreline properties will not have an adverse effect on the control of flooding provided the design of the development meets the following requirements:

1. The estimated regulatory flood level of 125.50 m.a.s.l. should be used in the design of any structures in the regulated area around Otter Lake. Any new structure (or addition to an existing structure) within the regulated area should be flood-proofed to prevent damage to the structure or its contents under 1:100 year flood conditions. The design of flood-proofing measures should include a minimum 30 cm freeboard above the regulatory flood level to provide an additional margin of safety, in consideration of uncertainties in the derivation of the regulatory flood level. The drawings submitted with the application should identify the proposed geodetic elevation of the structure and its foundation elements, and the flood proofing provisions in the design will be determined by the structure's relationship to the regulatory flood level.

2. Applications for approval of new residential buildings or additions that would enable an increase in the occupancy of existing residential buildings, in the regulated area will need to be accompanied by information on the access route to the building. Safe access to and egress from the site will be required under 1:100 year conditions. 30 cm (or less) of flood waters on access roads has typically been accepted as meeting safe access requirements, where flow velocities are not significant. Topographic surveys of access routes may be required.
3. In general, lot grading and site alteration should be designed to minimize the need for importation fill from off-site, and in all cases shall be designed so as to ensure no degradation – and enhancement where possible – of the ecological integrity and water quality protection functions of the shoreline and riparian zone.

## Closure

The hydrotechnical procedures used in this study to determine a regulatory flood level for Otter Lake conform to present day standards for flood hazard delineation, as set out in the MNR Natural Hazards Technical Guide (MNR, 2002). The computed flood elevations will be useful in the evaluation of applications for approval of development or site alteration in the regulated area and will also be of value in the flood forecasting and warning services of the RVCA.

The 1:100 year flood limits could not be drawn due to the inaccuracies of the available topographical information. In the absence of topographic mapping or digital elevation models of better accuracy and resolution, identifying the boundaries of hazardous lands with reasonable confidence requires on-site inspections and/or aerial photograph interpretation if suitable imagery is available.

The analysis has also provided information regarding the influence of the Otter Lake Road culvert and the downstream reach of Otter Creek on lake levels under extreme events, which may be of interest and use to the Township and lakeside residents.



Ferdous Ahmed, Ph.D., P.Eng.  
Senior Water Resources Engineer

## References:

1. Conservation Ontario (2005). Guidelines for Developing Schedules of Regulated Areas. Conservation Ontario and Ministry of Natural Resources, October 2005.
2. FHWA (1965). Hydraulic Charts for the Selection of Highway Culverts, Hydraulic Engineering Circular No. 5, US Federal Highway Administration, 1965.
3. FHWA (2001). Hydraulic Design of Highway Culverts, Publication No. FHWA-NHI-01-020, US Federal Highway Administration, September 2001.
4. Gingras, D., Adamowski, K., and Pilon, P.J. (1994) Regional Flood Equations for the Provinces of Ontario and Quebec. Water Resources Bulletin 30(1):55-67.
5. Haestad Methods (2007). Computer Application in Hydraulic Engineering. Bentley Press, Exton, PA, USA.
6. Pilon, P. J., and Harvey, D. (1993). CFA – Consolidated Frequency Analysis version 3.1. Environment Canada, Surveys and Information Systems Branch, Ottawa, March 1993.
7. MMAH (2005). 2005 Provincial Policy Statement. Ontario Ministry of Municipal Affairs and Housing, Queen’s Printer, Toronto, Ontario, 2005.
8. MNR (1986). Flood Plain Management in Ontario – Technical Guidelines. Ontario Ministry of Natural Resources, Conservation Authorities and Water Management Branch, Toronto.
9. MNR (2002). Technical Guide – River & Stream systems: Flooding Hazard Limit. Ontario Ministry of Natural Resources, Water Resources Section, Peterborough, Ontario, 2002.
10. MTO (1985). MTO Drainage Manual, Chapter D: Hydraulic Design of Culverts. Ontario Ministry of Transportation and Communications, Drainage and Hydrology Section, Downsview, August 1985.
11. MTO (1997). MTO Drainage Management Manual, Ministry of Transportation of Ontario, Drainage and Hydrology Section, October 1997.

12. RVCA (2007). Rideau River Watershed Modeling Using Mike11, Draft Report, Rideau Valley Conservation Authority, Manotick, Ontario, March 2007.
13. RVCA (2010). Estimation of Design Flows for RVCA Lakes. Technical Memo, Rideau Valley Conservation Authority, Manotick, Ontario, November 2010.
14. Smith, C. D. (1995). Hydraulic Structures. University of Saskatchewan, Canada.
15. Sturm, T. W. (2010). Open Channel Hydraulics. McGraw-Hill, New York, NY, USA.
16. US Corps of Engineers (1977). Shore Protection Manual. 3<sup>rd</sup> edition. US Army Coastal Research Center, Fort Belvoir, VA, USA, 1977.



**Table 1:** Estimated Flood Flows at Otter Lake Outlet

Return Period (years)	METHOD									
	Mike11 <sup>1</sup> (with outlet culvert)	Mike11 <sup>1</sup> (without outlet culvert)	FDRP <sup>2</sup>			Gingras et al. <sup>3</sup>				Area Pro-rating Method <sup>4</sup>
			Northern Ontario	Eastern Ontario	Ontario	Region: 7	Region: ON/QC	Region: 2	Region: 6	
2	2.01	4.52	3.77	7.50	3.49	7.17	9.17	20.32	3.22	
5	2.66	5.53	5.60	9.27	5.19					
10	3.07	6.12	6.88	10.35	6.39					
20	3.45	6.64	8.17	11.34	7.58	16.39	19.7	42.98	6.71	
50	3.94	7.28	10.44	13.32	9.73					
100	4.30	7.72	12.29	14.84	11.49	21.41	24.61	52.93	8.74	19.9
200	4.66	8.15								
500	5.14	8.69								

1. Mike11 output, using a Log Pearson Type 3 Frequency Distribution

2. MNR (1986). Flood Plain Management in Ontario – Technical Guidelines. Ontario Ministry of Natural Resources, Conservation Authorities and Water Management Branch, Toronto.

3. Gingras, D., Adamowski, K., and Pilon, P.J. (1994) Regional Flood Equations for the Provinces of Ontario and Quebec. Water Resources Bulletin 30(1):55-67.

4. Area Pro-rating method using streamflow measurements from the gauge: Rideau River at Carleton University (Station ID 02AL004; drainage area 3830 km<sup>2</sup>)

**Source:** RVCA (2010), Estimation of Design Flows for RVCA Lakes

**Table 2:** Computation of Headwater

Estimation Method	Return Period	Flow	Culvert Invert (d/s)	Culvert Diameter (D)	Critical Depth* (Y <sub>c</sub> )	Tailwater (TW) (D/2 + Y <sub>c</sub> /2)	Tailwater Elevation	Head Loss** (H)	Headwater (HW) (TW + H)	Headwater Elevation	Head Loss (HW - TW)
	years	cms	m	m	m	m	m	m	m	m	cm
Mike11 (with outlet culvert)	2	2.01	124.019	1.75	0.46	1.11	125.12	0.05	1.16	125.17	5
	5	2.66	124.019	1.75	0.55	1.15	125.17	0.08	1.23	125.25	8
	10	3.07	124.019	1.75	0.59	1.17	125.19	0.11	1.28	125.30	11
	20	3.45	124.019	1.75	0.65	1.20	125.22	0.15	1.35	125.37	15
	50	3.94	124.019	1.75	0.70	1.23	125.24	0.20	1.43	125.44	20
	100	4.30	124.019	1.75	0.74	1.25	125.26	0.24	1.49	125.50	24
	200	4.66	124.019	1.75	0.77	1.26	125.28	0.28	1.54	125.56	28
	500	5.14	124.019	1.75	0.82	1.29	125.30	0.32	1.61	125.62	32
Mike11 (without outlet culvert)	2	4.52	124.019	1.75	0.76	1.26	125.27	0.26	1.52	125.53	26
	5	5.53	124.019	1.75	0.86	1.31	125.32	0.36	1.67	125.68	36
	10	6.12	124.019	1.75	0.90	1.33	125.34	0.45	1.78	125.79	45
	20	6.64	124.019	1.75	0.95	1.35	125.37	0.53	1.88	125.90	53
	50	7.28	124.019	1.75	1.00	1.38	125.39	0.64	2.02	126.03	64
	100	7.72	124.019	1.75	1.04	1.40	125.41	0.73	2.13	126.14	73
	200	8.15	124.019	1.75	1.07	1.41	125.43	0.82	2.23	126.25	82
	500	8.69	124.019	1.75	1.11	1.43	125.45	0.91	2.34	126.36	91

\* Calculated using Design Chart D5-3F (MTO, 1985)

\*\* Calculated using Design Chart D5-2F (MTO, 1985)

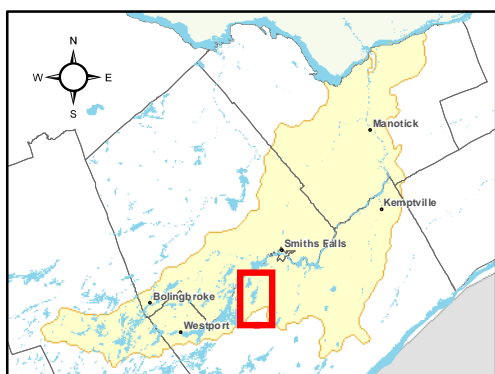
**NOTE:** The computations were completed for both outlet and inlet control; however only the governing scenario (outlet control) is shown above.

**Table 3:** Regulatory Flood Level (RFL) of Otter Lake

<b>Return Period</b>	<b>Flow</b>	<b>Computed Water Surface Elevation</b>	<b>RFL</b>
years	cms	m	m
2	2.01	125.17	
5	2.66	125.25	
10	3.07	125.30	
20	3.45	125.37	
50	3.94	125.44	
100	4.30	125.50	125.50
200	4.66	125.56	
500	5.14	125.62	



**Figure 1: Location Map**



**Legend**

- Otter Lake Subwatershed
- Freeway
- Expressway / Highway
- Collector
- Local / Street
- Private/Rural



Projection note: U.T.M. Zone 18 - NAD 83 Datum

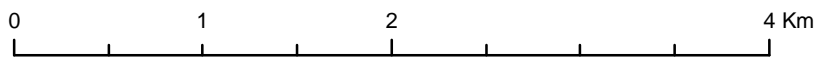
Map Scale: 1:40,000

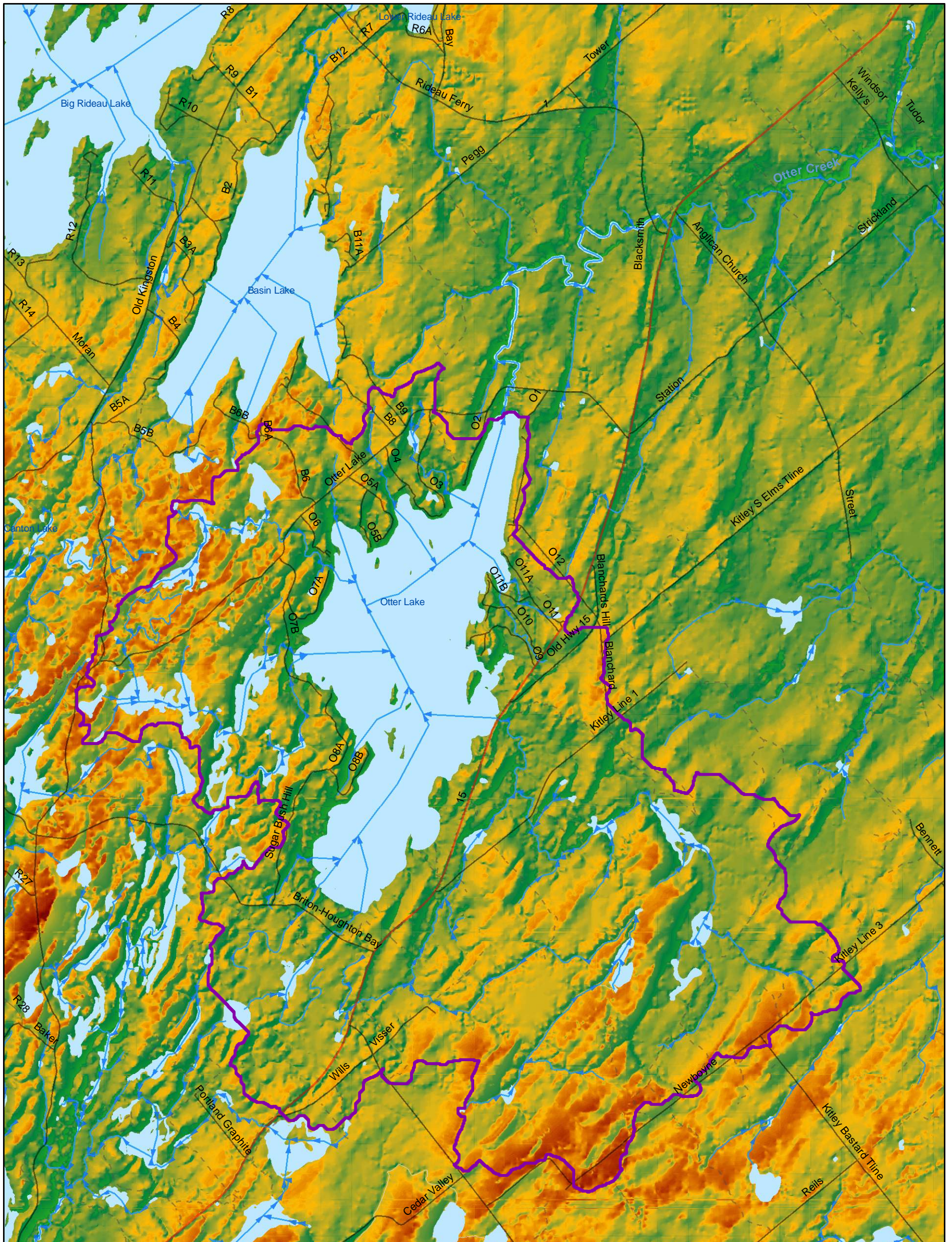
Date Modified: 5/11/2011

Created by: sschreiner

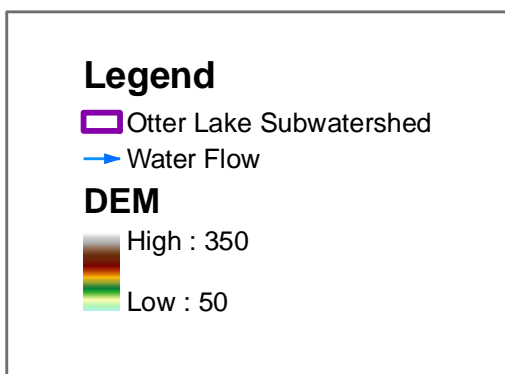
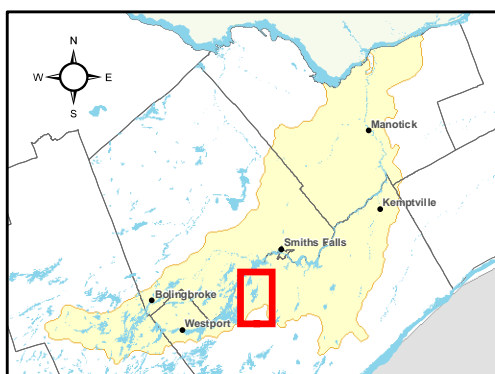
Base-mapping and GIS services provided courtesy of the Rideau Valley Conservation Authority, under License with the Ontario Ministry of Natural Resources © Queen's Printer for Ontario, 2008.

These maps are the property of the RVCA, and the RVCA holds a copyright on them. These maps may be copied or reproduced by other parties provided that the RVCA is properly acknowledged as the original source of the information in any document, report or map in which this mapping is used, and provided that no fee is charged (other than to cover handling charges). While RVCA makes every effort to ensure that the information presented is sufficiently accurate for the intended uses of the map, there is an inherent margin of error in all mapping products, and the RVCA cannot guarantee the accuracy of the mapping for all possible uses. All end-users of the information contained herein must therefore determine for themselves if the information is of suitable accuracy for their purposes.





**Figure 2: Otter Lake Basin**



Projection note: U.T.M. Zone 18 - NAD 83 Datum

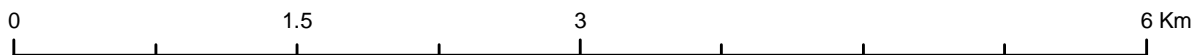
Map Scale: 1:40,000

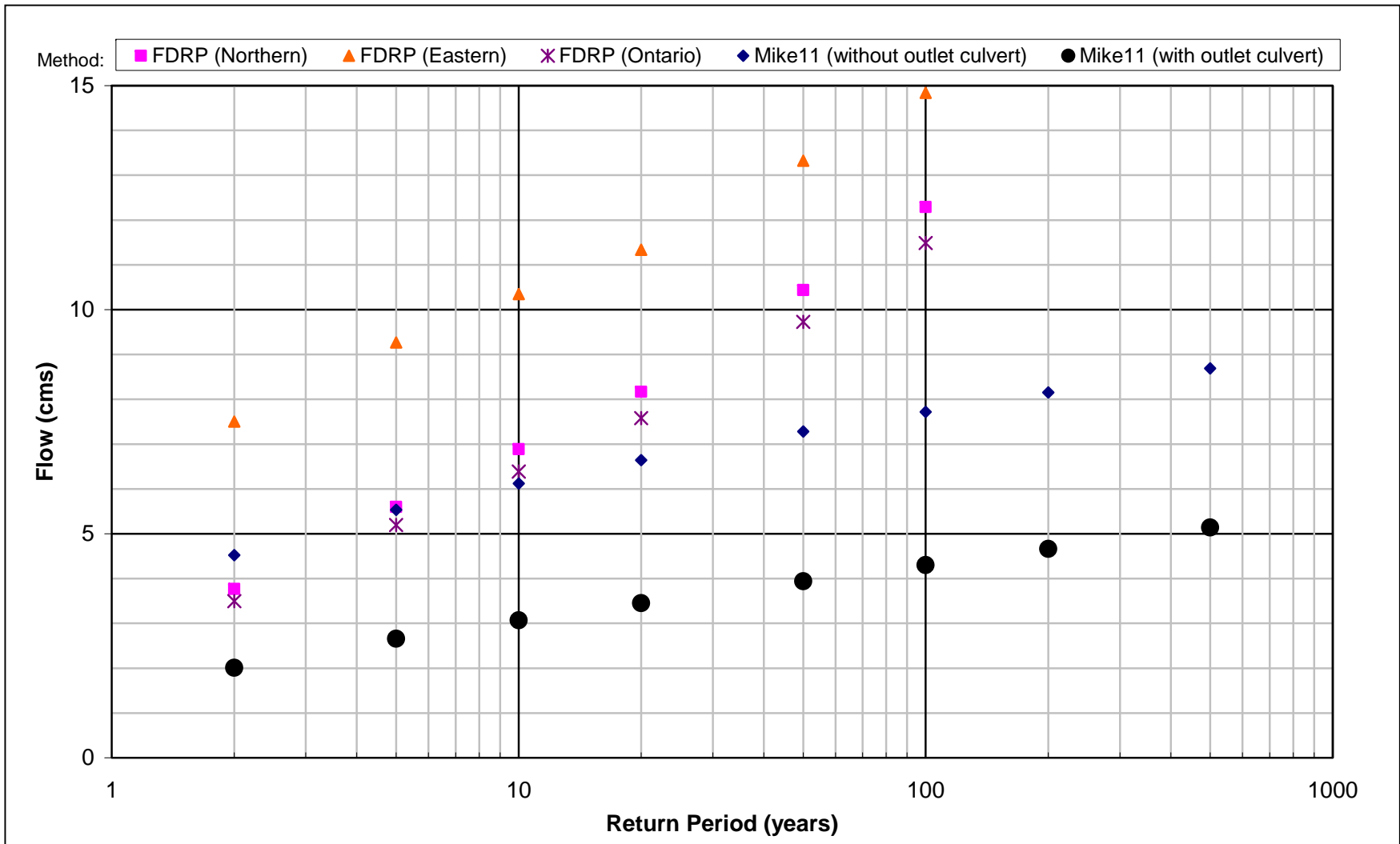
Date Modified: 5/09/2011

Created by: sschreiner

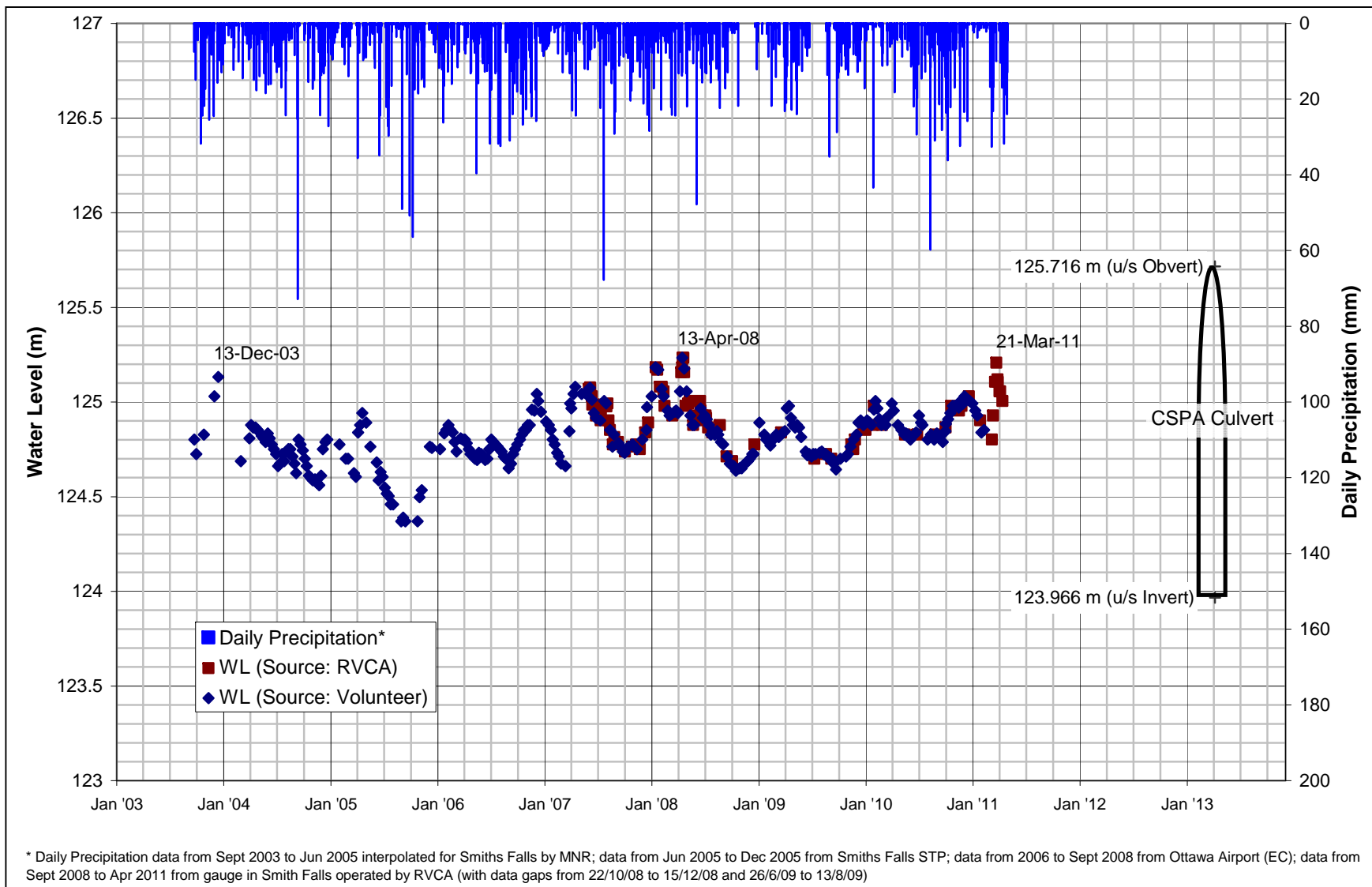
Base-mapping and GIS services provided courtesy of the Rideau Valley Conservation Authority, under License with the Ontario Ministry of Natural Resources © Queen's Printer for Ontario, 2008.

These maps are the property of the RVCA, and the RVCA holds a copyright on them. These maps may be copied or reproduced by other parties provided that the RVCA is properly acknowledged as the original source of the information in any document, report or map in which this mapping is used, and provided that no fee is charged (other than to cover handling charges). While RVCA makes every effort to ensure that the information presented is sufficiently accurate for the intended uses of the map, there is an inherent margin of error in all mapping products, and the RVCA cannot guarantee the accuracy of the mapping for all possible uses. All end-users of the information contained herein must therefore determine for themselves if the information is of suitable accuracy for their purposes.



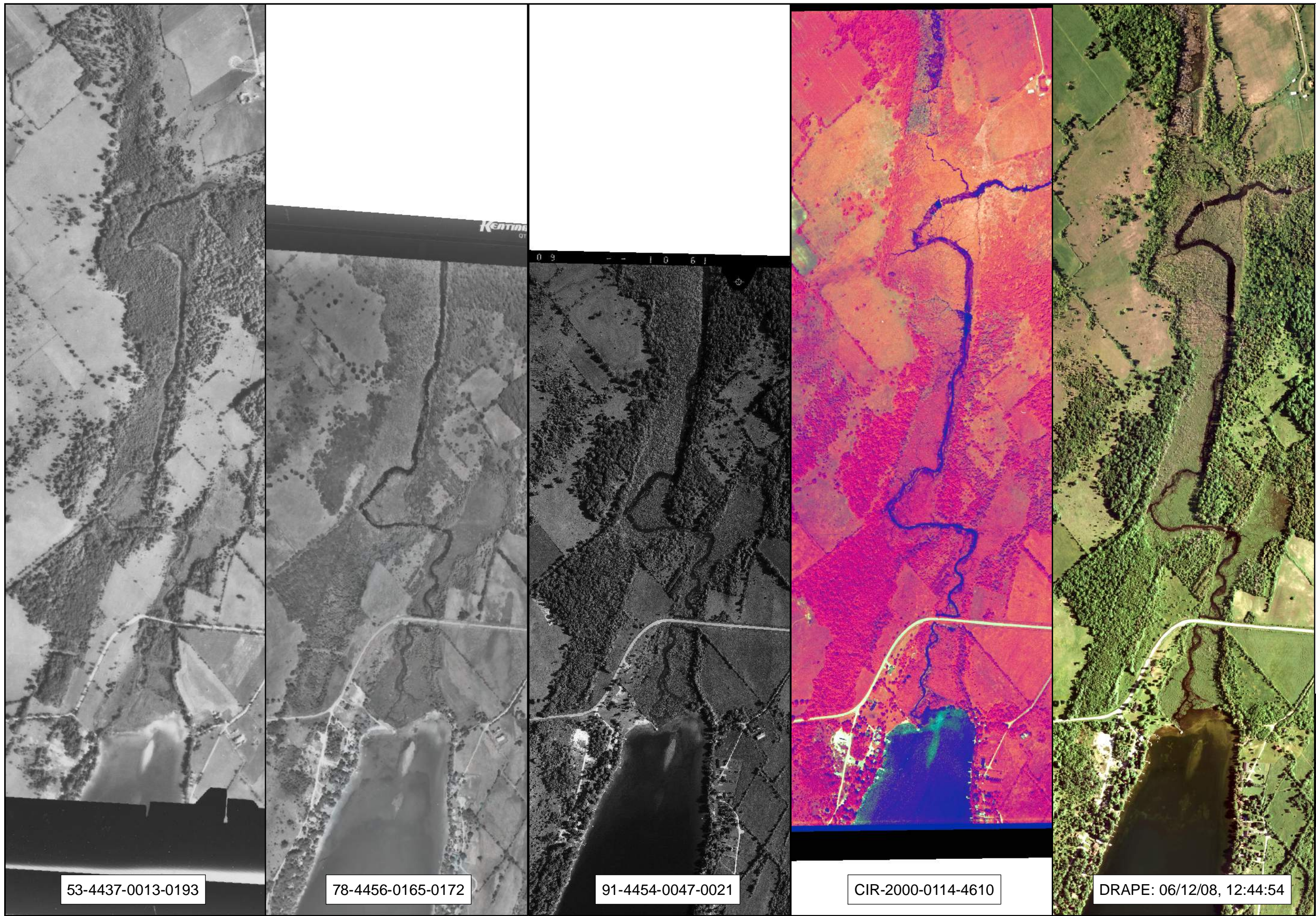


**Figure 3:** Estimated Flood Flows



**Figure 4:** Water Level Measurements Near Otter Lake Outlet and Recorded Precipitation

**Figure 5:  
Otter Lake Outlet,  
Historical Air Photos**



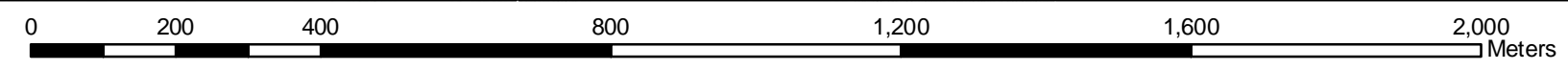
53-4437-0013-0193

78-4456-0165-0172

91-4454-0047-0021

CIR-2000-0114-4610

DRAPE: 06/12/08, 12:44:54



**RIDEAU VALLEY  
CONSERVATION AUTHORITY**

Map Scale: 1:10,000

Projection note: U.T.M. Zone 18 - NAD 83 Datum

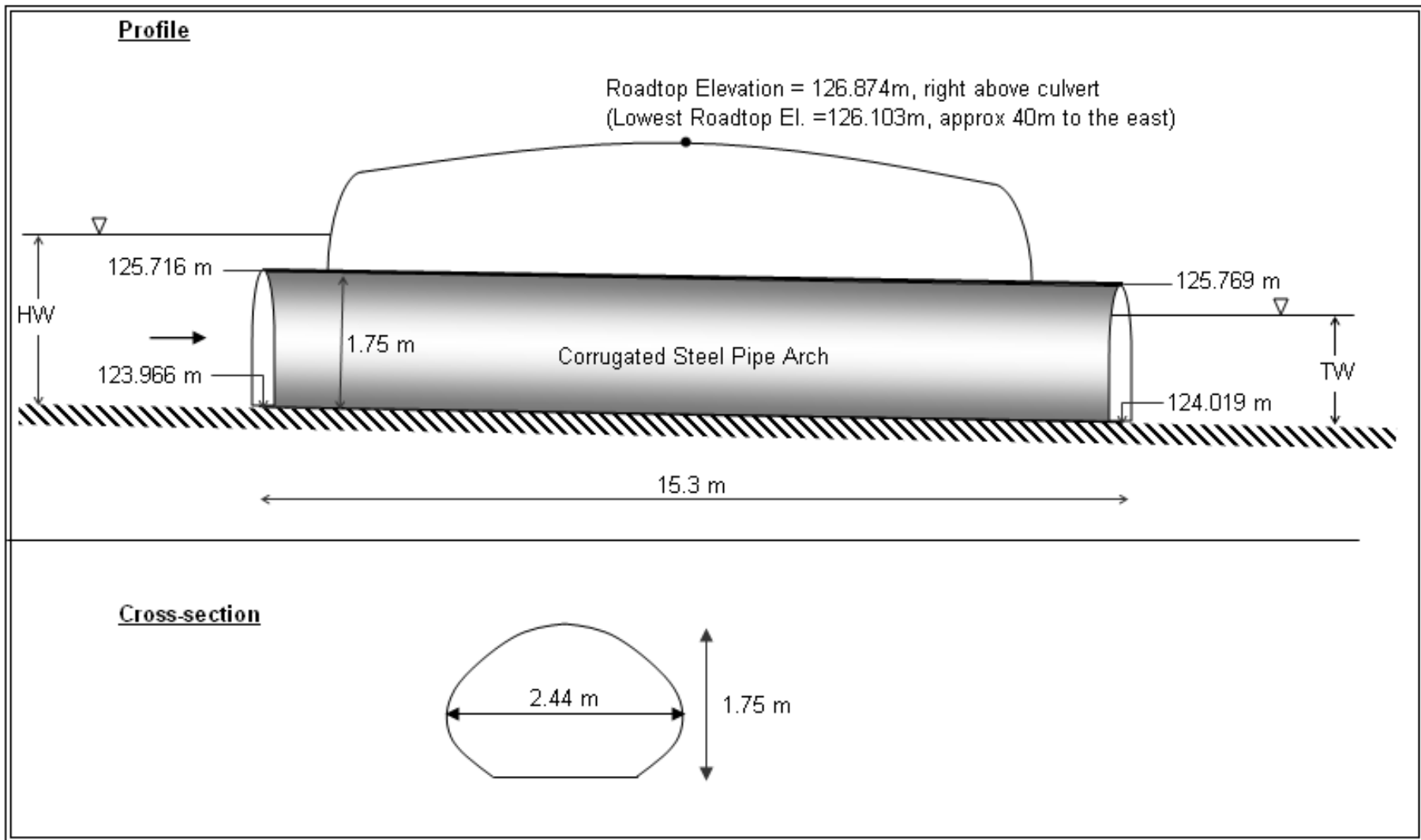
File Location: \\rvca\rvca\GIS\MapServer\workspace\otterlake\otterlake\_061208\_124454.apr

Created by: jforjet	Date Modified: 5/11/2011 11:53:50 AM
Modified by: dlines	Date Published: 5/16/2011
Published by: sashreiner	

Base-mapping and GIS services provided courtesy of the Rideau Valley Conservation Authority, under License with the Ontario Ministry of Natural Resources © Queen's Printer for Ontario, 2008.

These maps are the property of the RVCA, and the RVCA holds a copyright on them. These maps may be copied or reproduced by other parties provided that the RVCA is properly acknowledged as the original source of the information in any document, report or map in which this mapping is used, and provided that no fee is charged (other than to cover handling charges). While RVCA makes every effort to ensure that the information presented is sufficiently accurate for the intended uses of the map, there is an inherent margin of error in all mapping products, and the RVCA cannot guarantee the accuracy of the mapping for all possible uses. All end-users of the information contained herein must therefore determine for themselves if the information is of suitable accuracy for their purposes.





**Figure 6:** Culvert under Otter Lake Road

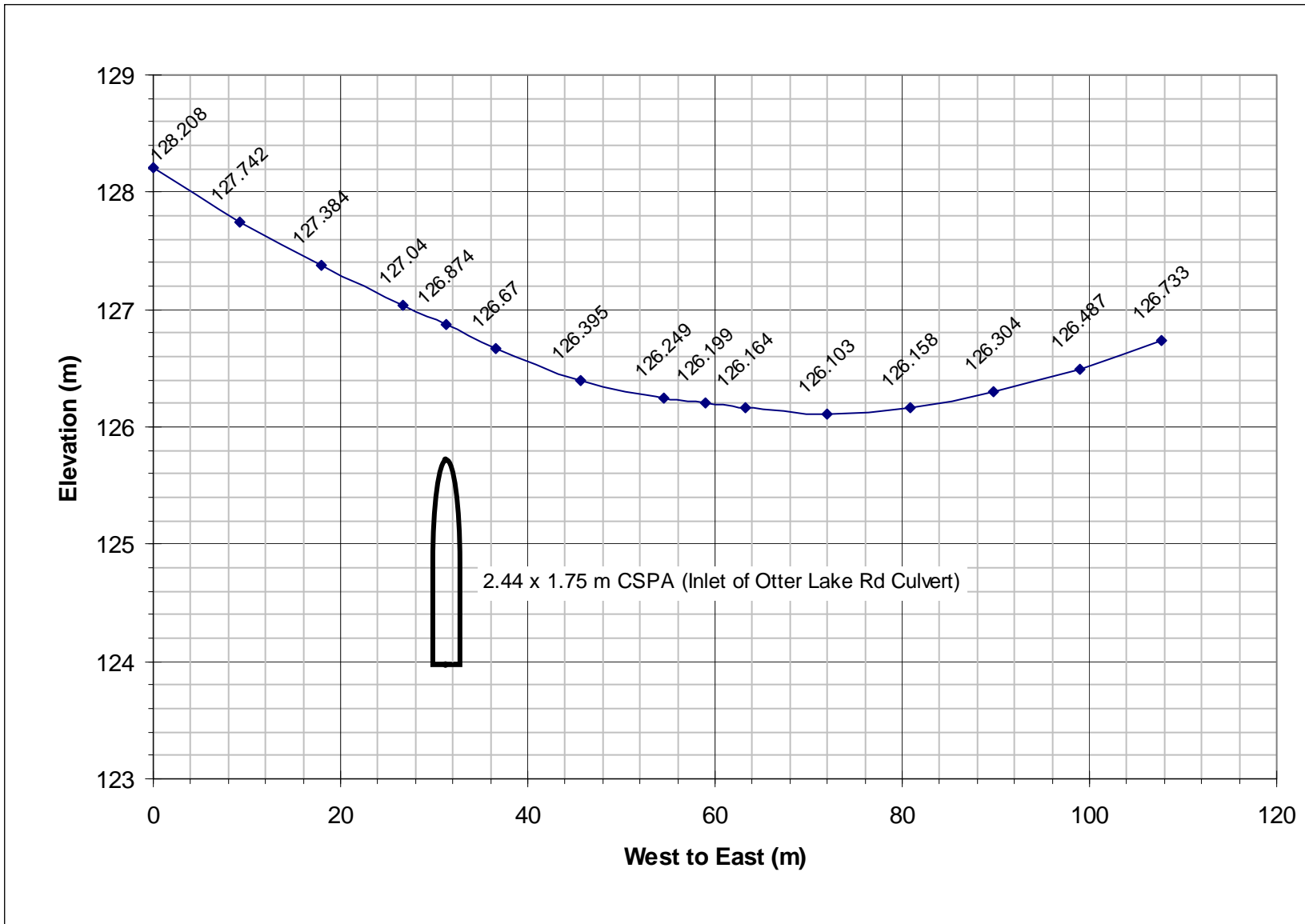


Figure 7: Otter Lake Road Profile and Culvert



Otter Lake Inlet



Looking upstream towards Otter Lake

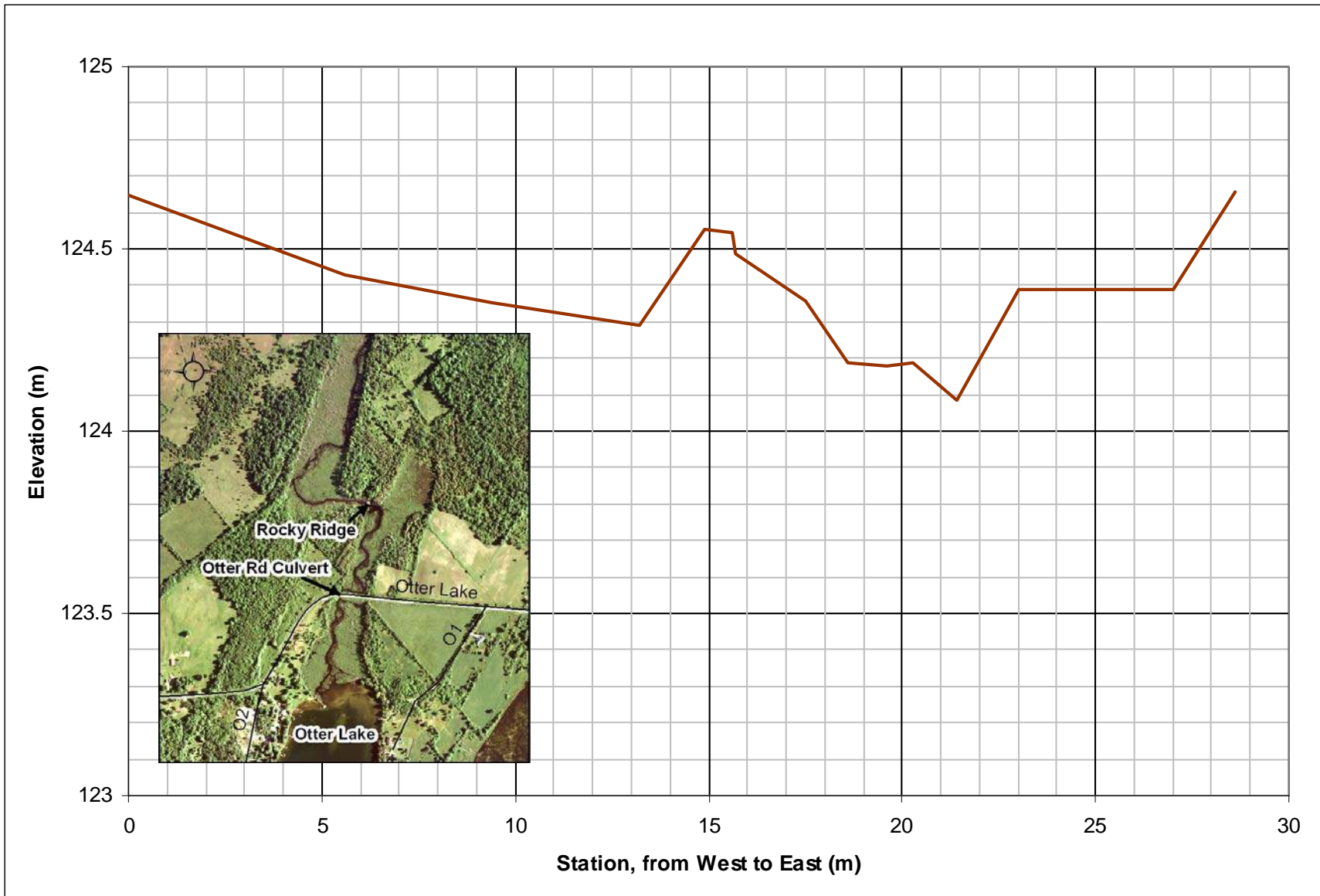


Otter Lake Outlet

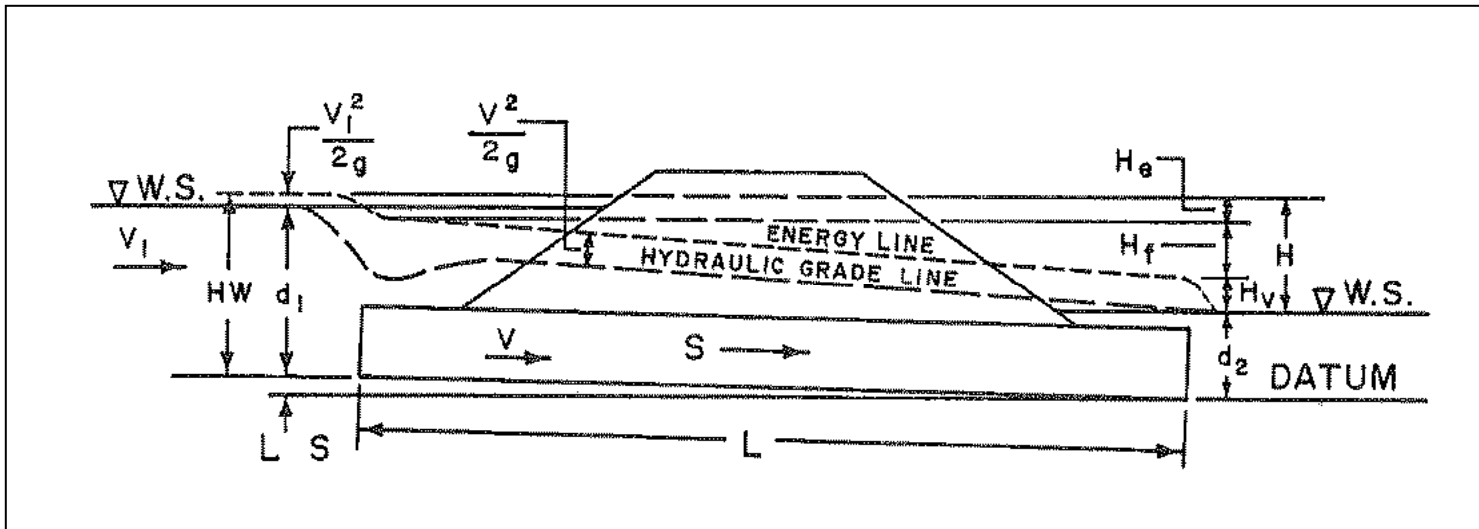


Looking downstream along Otter Creek

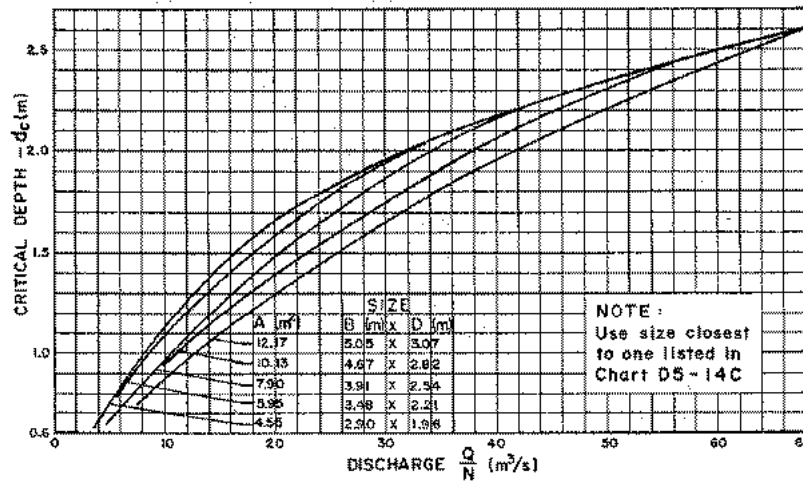
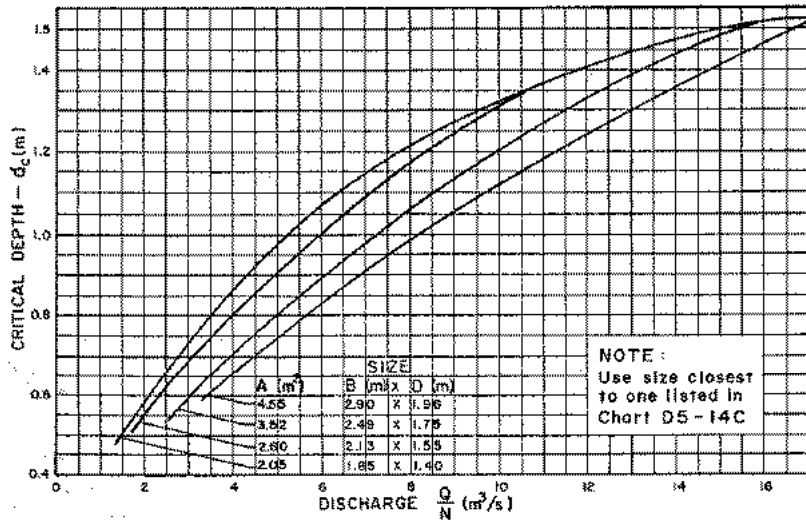
**Figure 8:** Photos of Otter Lake Outlet (taken March 22, 2011)



**Figure 9:** Rock Ledge Cross-section (d/s of Otter Lake Rd culvert)



**Figure 10:** Culvert Computation - Definition Sketch (Source: MTO 1985, Fig D3-3)



( $d_c \neq D$ )

A = Cross-sectional area per barrel.  
 Other sizes to be interpolated



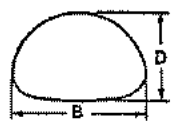
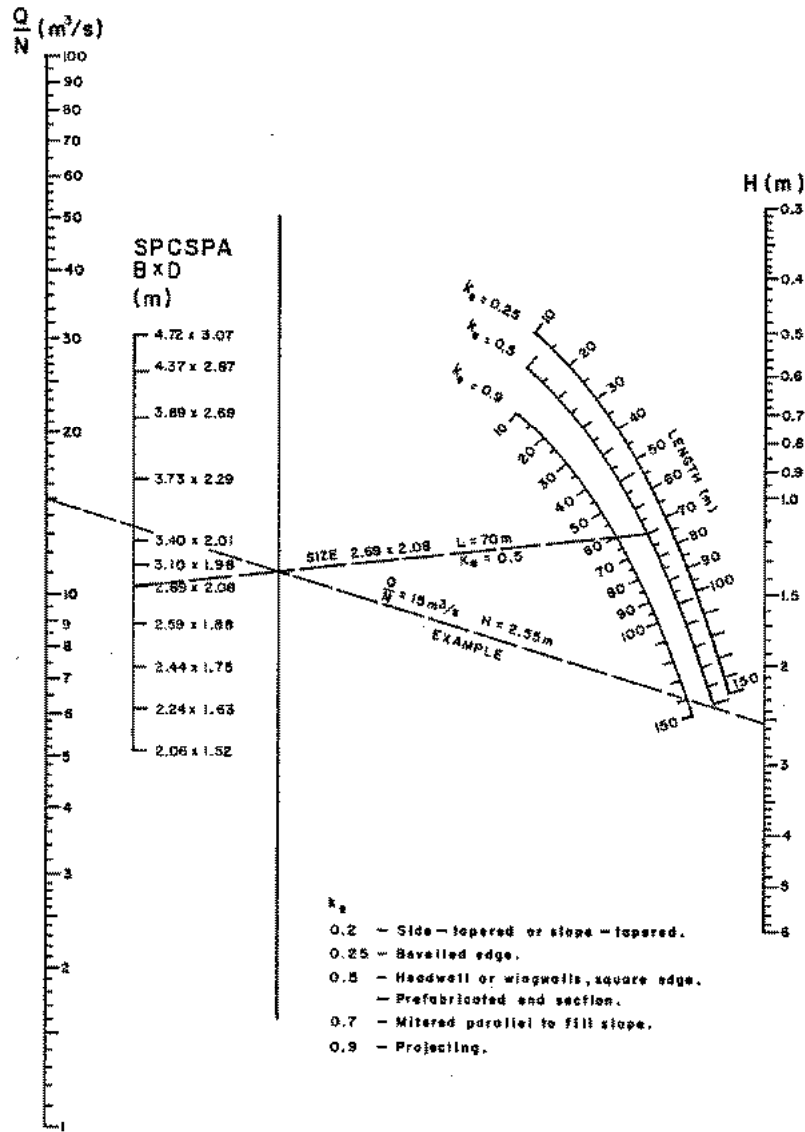
**CRITICAL DEPTH  
 STRUCTURAL PLATE  
 CORRUGATED STEEL PIPE ARCH**

FHA 64 01  
 METRIC FHA 74 08 (51)

1985 05 16

DC-27

Figure 11: MTO (1985) Chart D5-3F



**OUTLET CONTROL  
 STRUCTURAL PLATE  
 CORRUGATED STEEL PIPE ARCH  
 FLOWING FULL  
 $n = 0.0327 \text{ TO } 0.0306$**

FHA 63 01  
 METRIC FHA 74 08 (51)

1985 05 16

DC-20

Figure 12: MTO (1985) Chart D5-2F

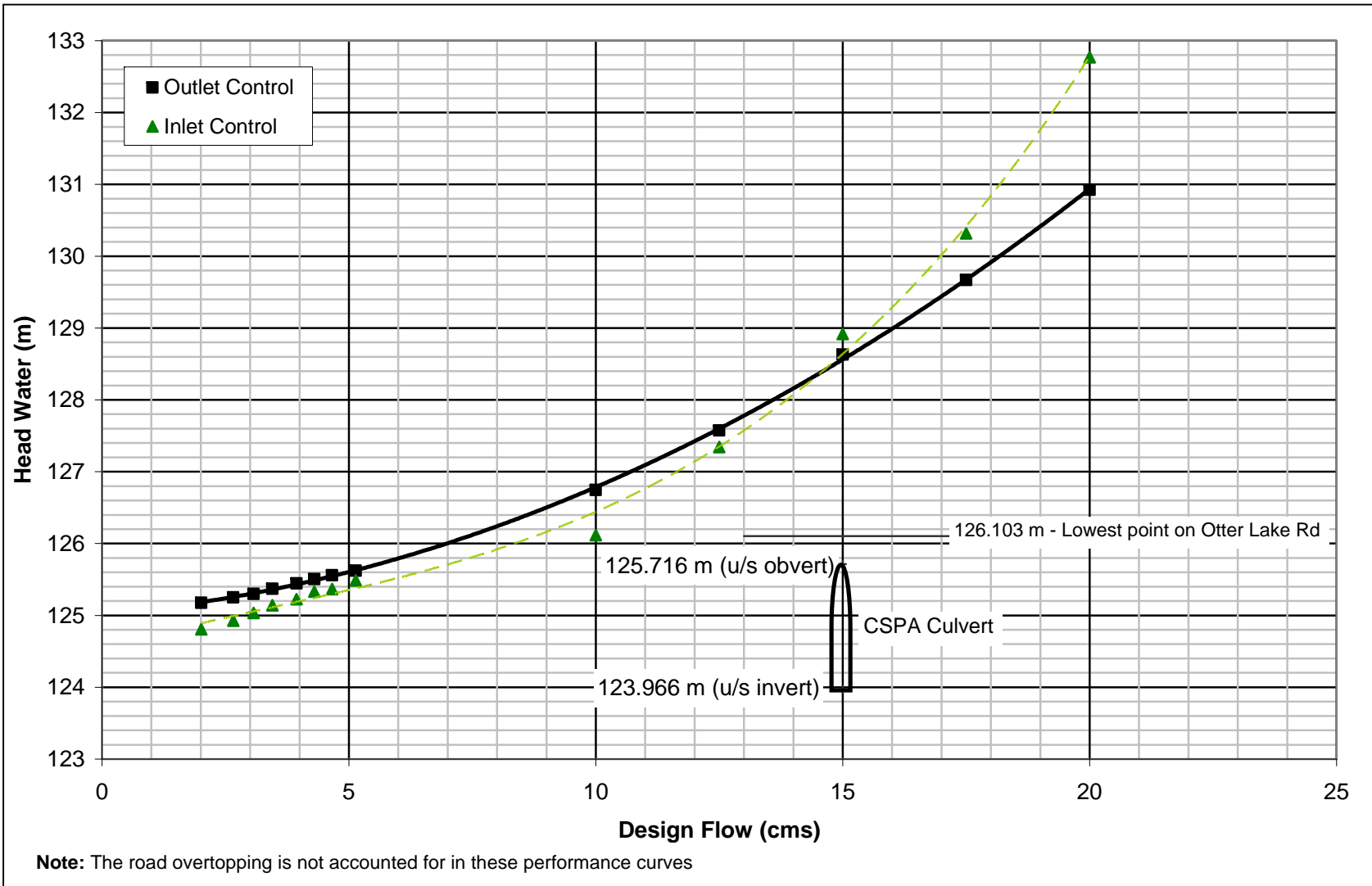
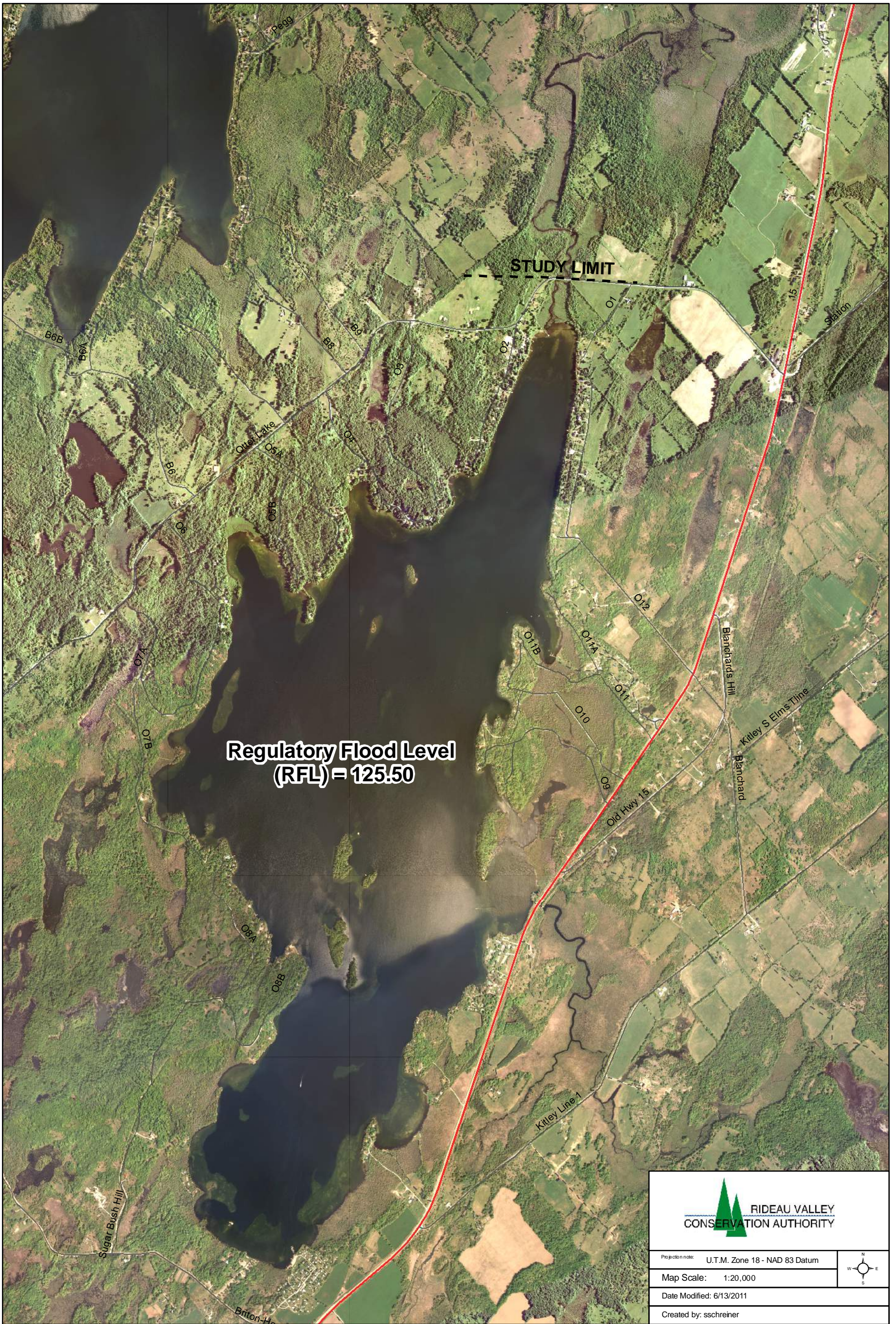
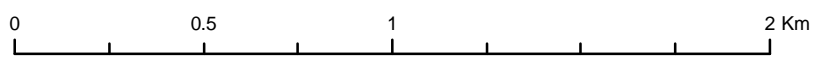



Figure 13: Performance Curve of Otter Lake Road Culvert

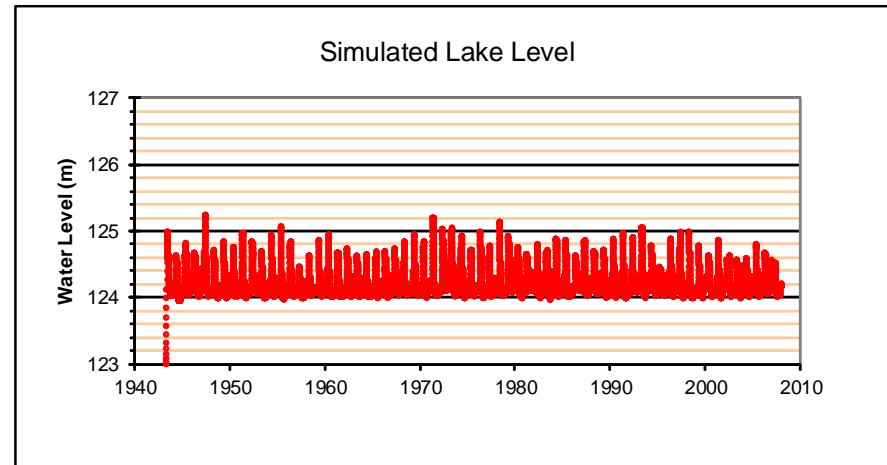
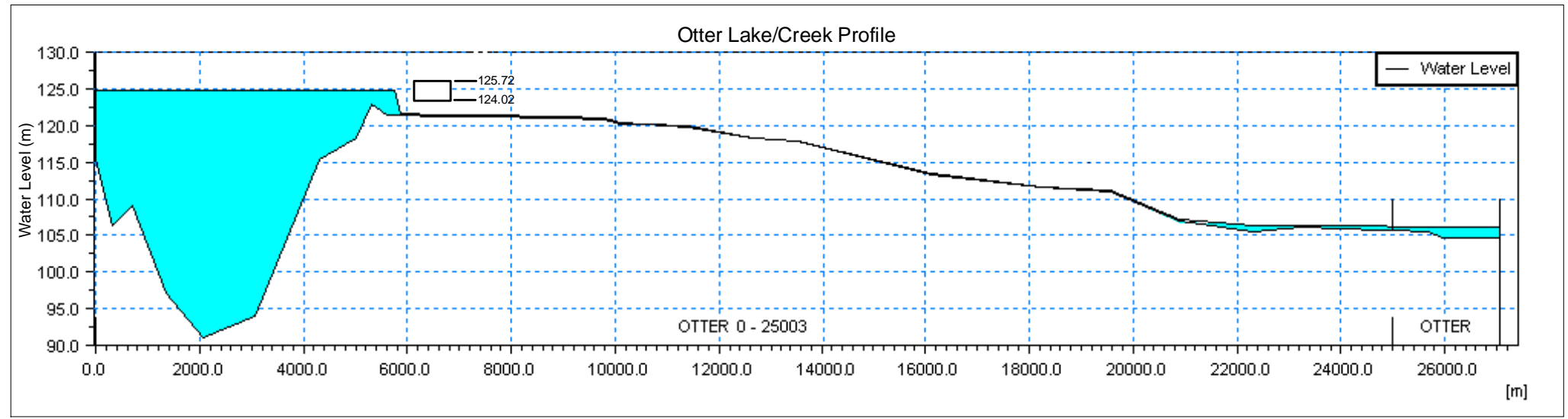
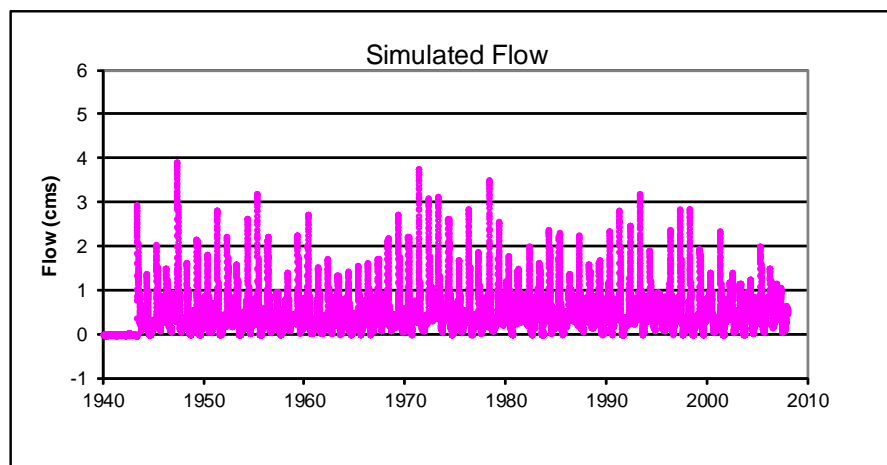
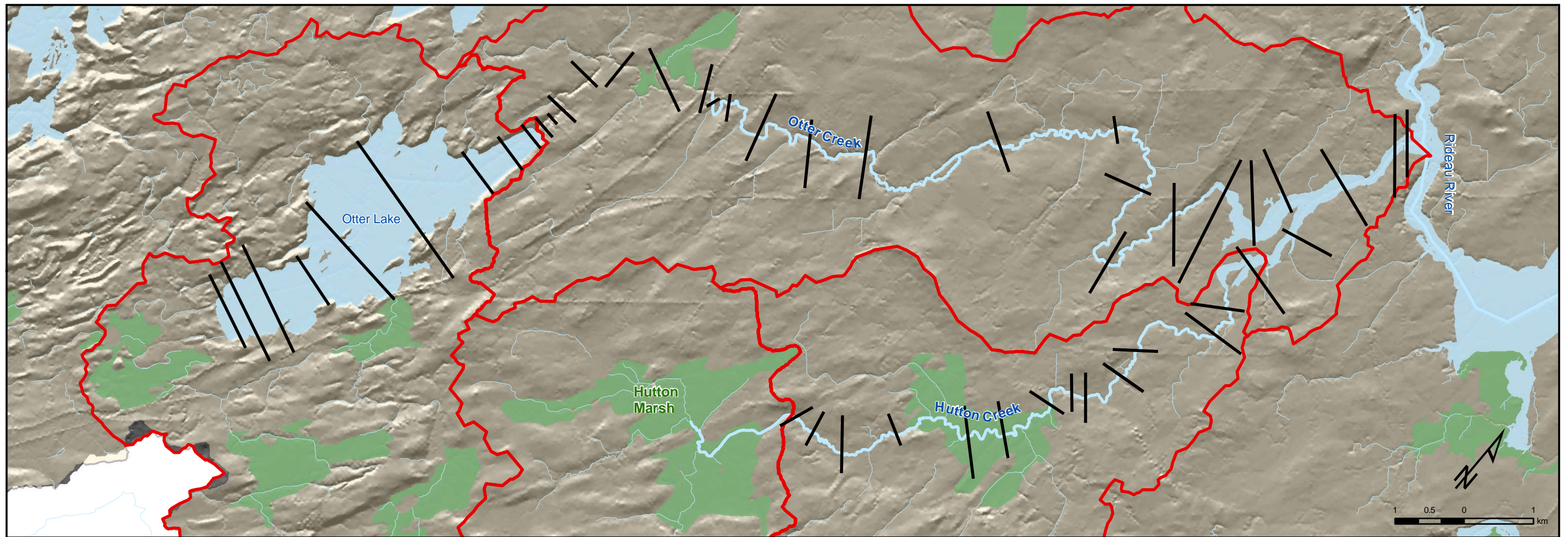




**Figure 14: Regulatory Flood Elevation on Otter Lake**



	
Projection note:	U.T.M. Zone 18 - NAD 83 Datum
Map Scale:	1:20,000
Date Modified:	6/13/2011
Created by:	sschreiner
<small>Base-mapping and GIS services provided courtesy of the Rideau Valley Conservation Authority, under License with the Ontario Ministry of Natural Resources © Queen's Printer for Ontario, 2008.</small>	
<small>These maps are the property of the RVCA, and the RVCA holds a copyright on them. These maps may be copied or reproduced by other parties provided that the RVCA is properly acknowledged as the original source of the information in any document, report or map in which this mapping is used, and provided that no fee is charged (other than to cover handling charges). While RVCA makes every effort to ensure that the information presented is sufficiently accurate for the intended uses of the map, there is an inherent margin of error in all mapping products, and the RVCA cannot guarantee the accuracy of the mapping for all possible uses. All end-users of the information contained herein must therefore determine for themselves if the information is of suitable accuracy for their purposes.</small>	



**Figure 15**  
**Mike 11 Model of Otter - Hutton System**

Base-mapping and GIS services provided courtesy of the Rideau Valley Conservation Authority, under License with the Ontario Ministry of Natural Resources © Queen's Printer for Ontario, 2011.

These maps are the property of the RVCA, and the RVCA holds a copyright on them. These maps may be copied or reproduced by other parties provided that the RVCA is properly acknowledged as the original source of the information in any document, report or map in which this mapping is used, and provided that no fee is charged (other than to cover handling charges).

While RVCA makes every effort to ensure that the information presented is sufficiently accurate for the intended uses of the map, there is an inherent margin of error in all mapping products, and the RVCA cannot guarantee the accuracy of the mapping for all possible uses. All end-users of the information contained herein must therefore determine for themselves if the information is of suitable accuracy for their purposes.